

*NHERI Lehigh Researcher's Workshop: Advanced Simulation for Natural Hazards Mitigation, Lehigh, December 5-6, 2016*

# MDOF Hybrid Shake Table Testing of Response Modification Devices

Andreas Schellenberg, Ph.D., P.E.

Shawn You, Ph.D., P.E.

Stephen Mahin, Ph.D.



# Outline of Presentation

1. Motivation
2. Hybrid Shake Table Testing
3. Stability and Accuracy Considerations
4. Test Rehearsal and Safety Precautions
5. Bridge Application
6. Building Application
7. Summary & Conclusions

# Motivation

- ★ Many structures exhibit significant rate of loading effects
- ★ Need testing to occur at or near real time
- ★ Large systems such as tall buildings, long-span bridges, or SFSI are difficult to test on shake tables

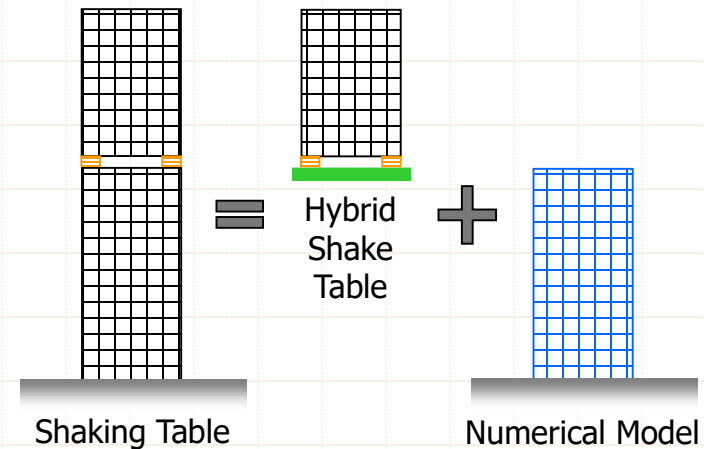
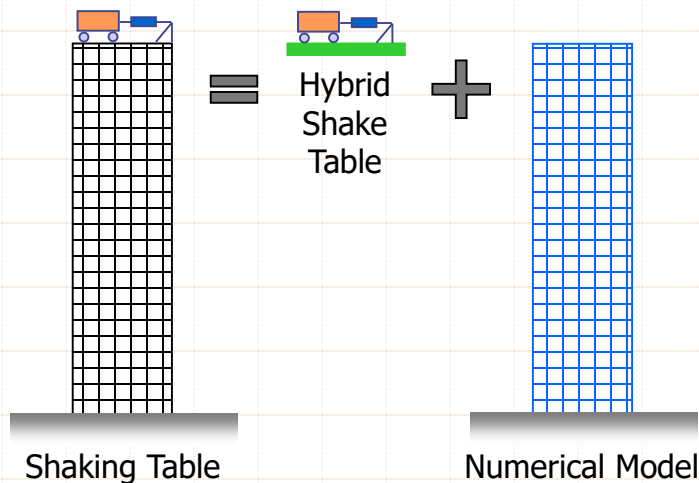

# Hybrid Shake Table Testing

$$\mathbf{M} \cdot \ddot{\mathbf{u}} + \mathbf{C} \cdot \dot{\mathbf{u}} + \mathbf{P}_r(\mathbf{u}, \dot{\mathbf{u}}, \ddot{\mathbf{u}}) = \mathbf{P}(t)$$



- ★ Inertia
- ★ Energy Dissipation
- ★ Resistance

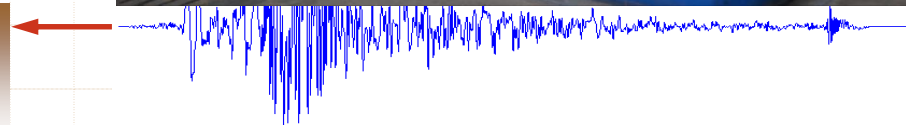

# Hybrid Shake Table Configuration

Tall Building Application

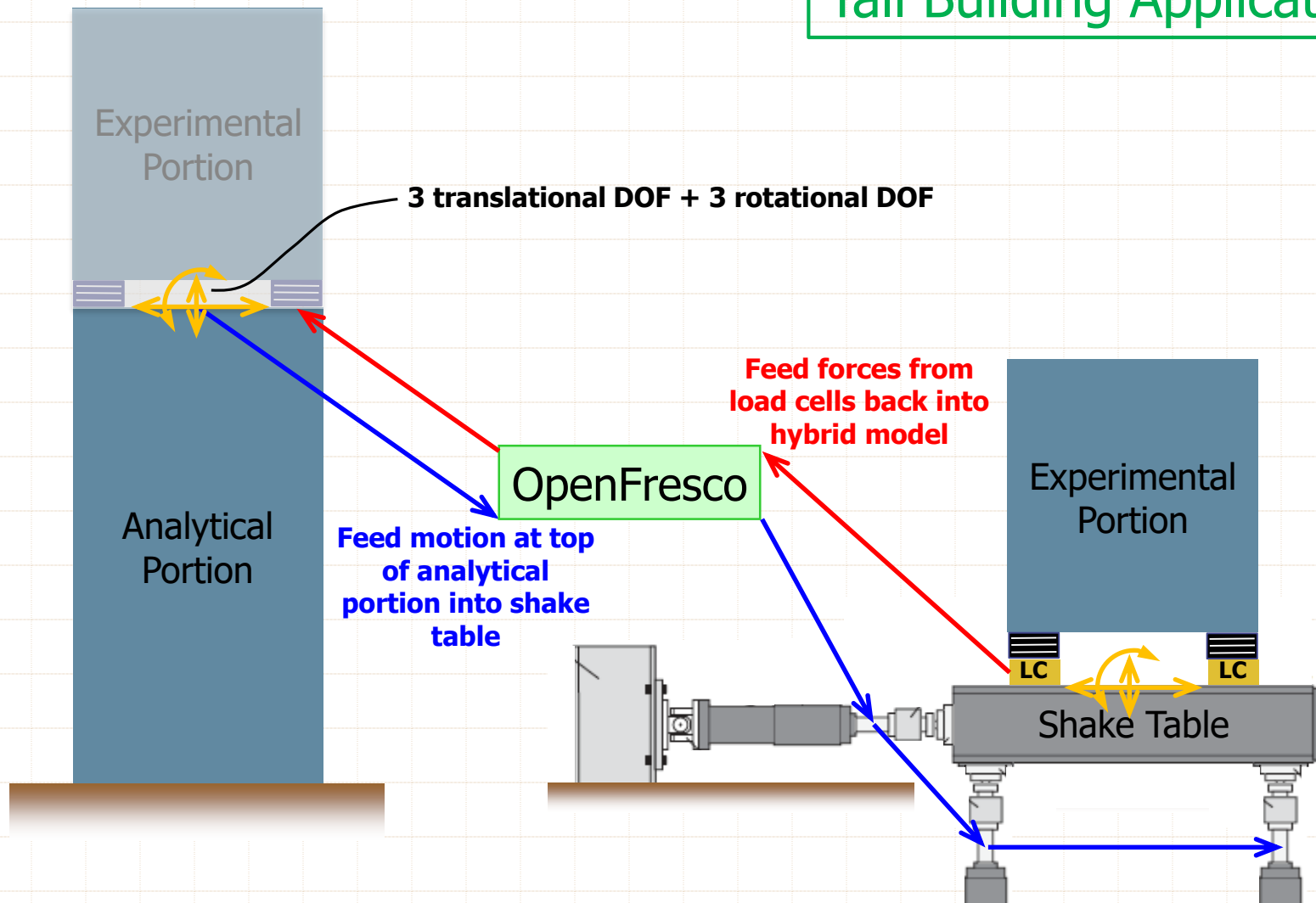

# Hybrid Shake Table Configuration

Long-Span Bridge Application

1 actuator DOF + 2 table DOF

■ Analytical Portion  
■ Experimental Portion

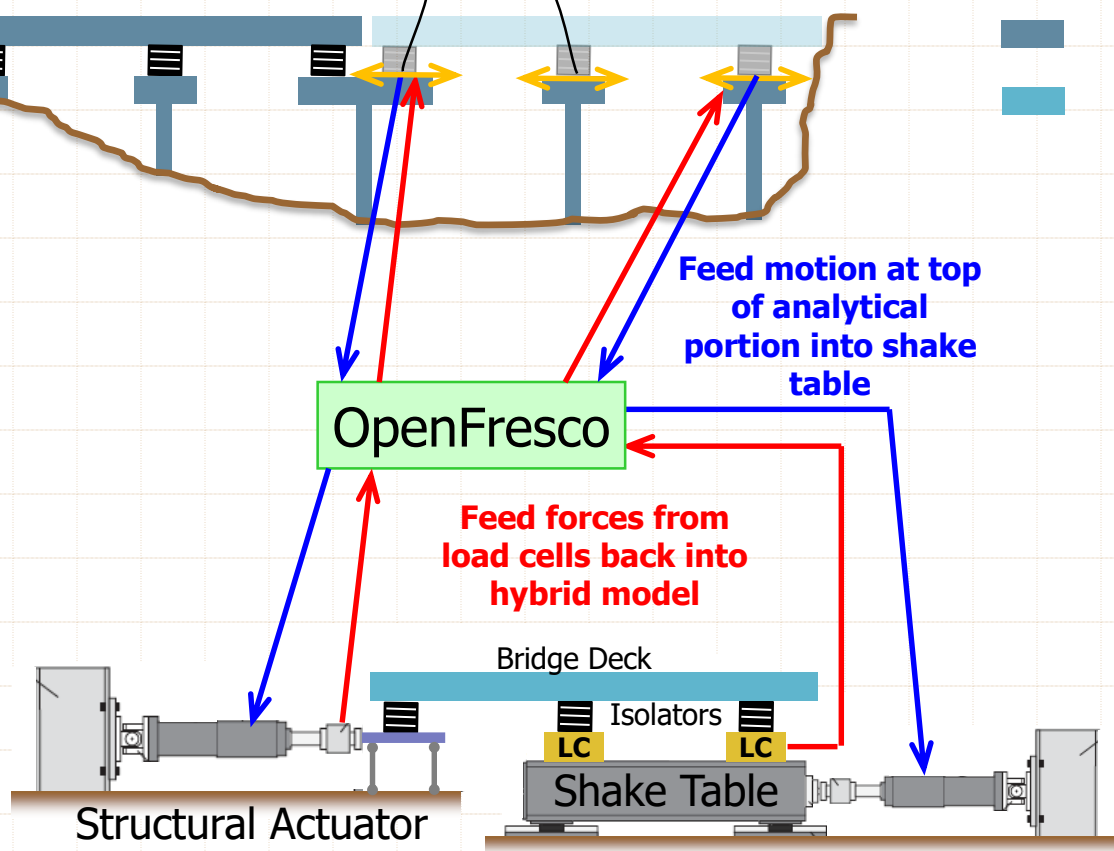

# Equations of Motion

## 1. Slow test

$$\mathbf{M}\ddot{\mathbf{U}}_{i+1} + \mathbf{C}\dot{\mathbf{U}}_{i+1} + \mathbf{P}_r^A(\mathbf{U}_{i+1}, \dot{\mathbf{U}}_{i+1}) + \mathbf{P}_r^E(\mathbf{U}_{i+1}) = \mathbf{P}_{i+1} - \mathbf{P}_{0,i+1}$$

## 2. Rapid test

$$\mathbf{P}_r^E(\mathbf{U}_{i+1}) = \mathbf{P}_{r,i+1} - \mathbf{M}^E \ddot{\mathbf{U}}_{i+1}^E - \mathbf{C}^E \dot{\mathbf{U}}_{i+1}^E$$

## 3. Real-time test

$$\mathbf{M}^A \ddot{\mathbf{U}}_{i+1} + \mathbf{C}^A \dot{\mathbf{U}}_{i+1} + \mathbf{P}_r^A(\mathbf{U}_{i+1}, \dot{\mathbf{U}}_{i+1}) + \mathbf{P}_r^E(\mathbf{U}_{i+1}, \dot{\mathbf{U}}_{i+1}, \ddot{\mathbf{U}}_{i+1}) = \mathbf{P}_{i+1} - \mathbf{P}_{0,i+1}$$

$$\mathbf{P}_r^E(\mathbf{U}_{i+1}, \dot{\mathbf{U}}_{i+1}, \ddot{\mathbf{U}}_{i+1}) = \mathbf{P}_{r,i+1} + \mathbf{M}^E \ddot{\mathbf{U}}_{i+1}$$

## 4. Smart shaking table test

$$\mathbf{P}_r^E(\mathbf{U}_{t,i+1}, \dot{\mathbf{U}}_{t,i+1}, \ddot{\mathbf{U}}_{t,i+1}) = \mathbf{P}_{r,i+1} + \mathbf{M}^E \ddot{\mathbf{U}}_{t,i+1}$$

# Important Analysis Parameters

- ★ OpenSees or OpenSees<sup>SP</sup> as comp. driver
- ★ Using AlphaOSGeneralized ( $\rho_{inf} = 0$ )
- ★ Next time try KRAAlphaExplicit method
- ★ No iterations necessary
- ★ Using MultipleSupport excitation pattern in OpenSees to get **absolute** response
- ★ Gravity loads on test specimen always present → apply gravity loads to numerical portion **before** connecting with shake table + apply disp. commands relative to start of test



# Connecting to MTS 469D + FlexTest

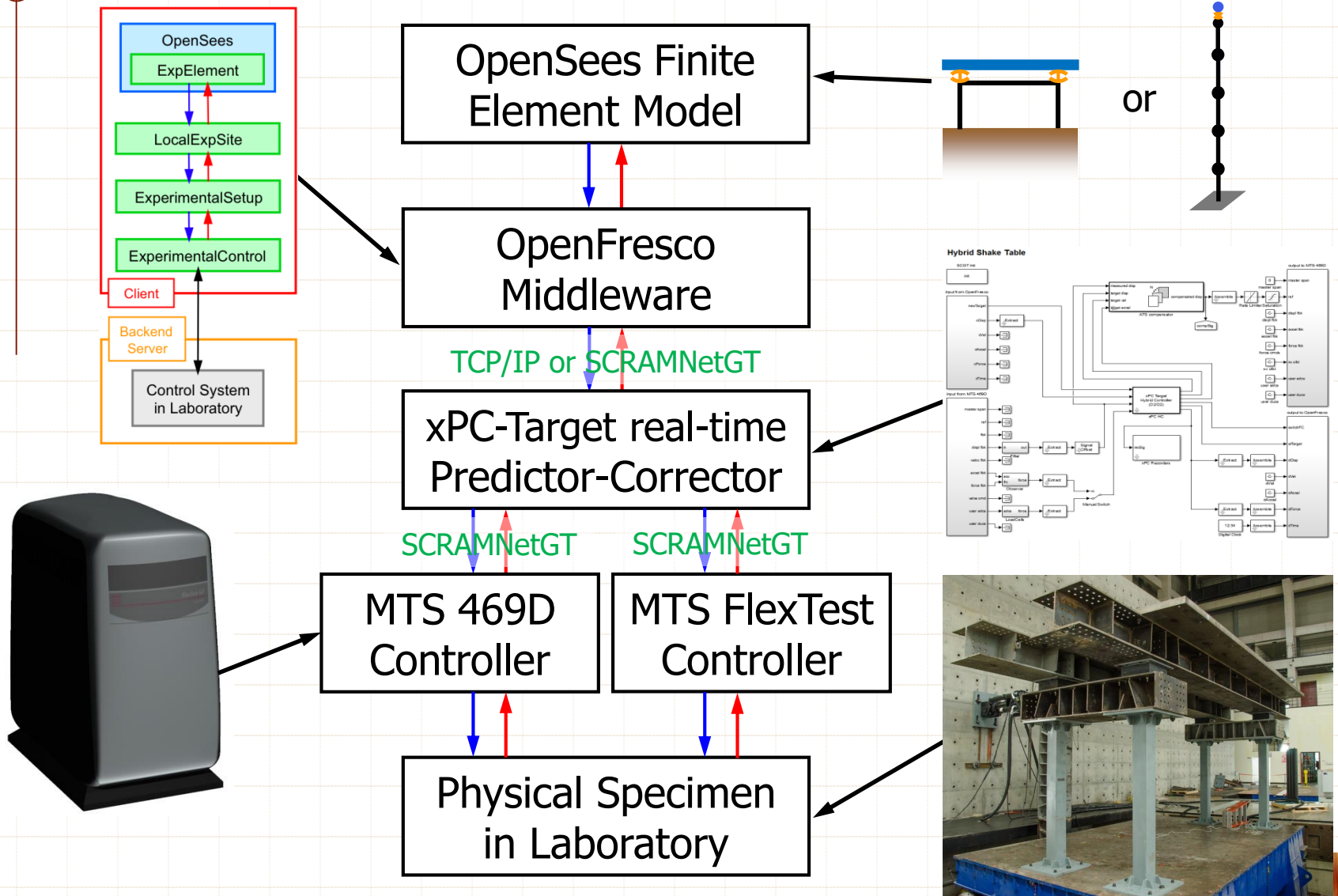

# Improving Stability & Accuracy

- ★ Delay compensation is essential for real-time hybrid simulations (RTHS)
- ★ Use Adaptive Time Series (ATS) delay compensator (by Y. Chae)
- ★ Modify ATS to use target velocities and accelerations computed by predictor-corrector algorithm instead of taking derivatives of target displacements
- ★ Use stabilization and loop-shaping
- ★ Sensor noise reduction by filtering fbk

# Three-loop architecture

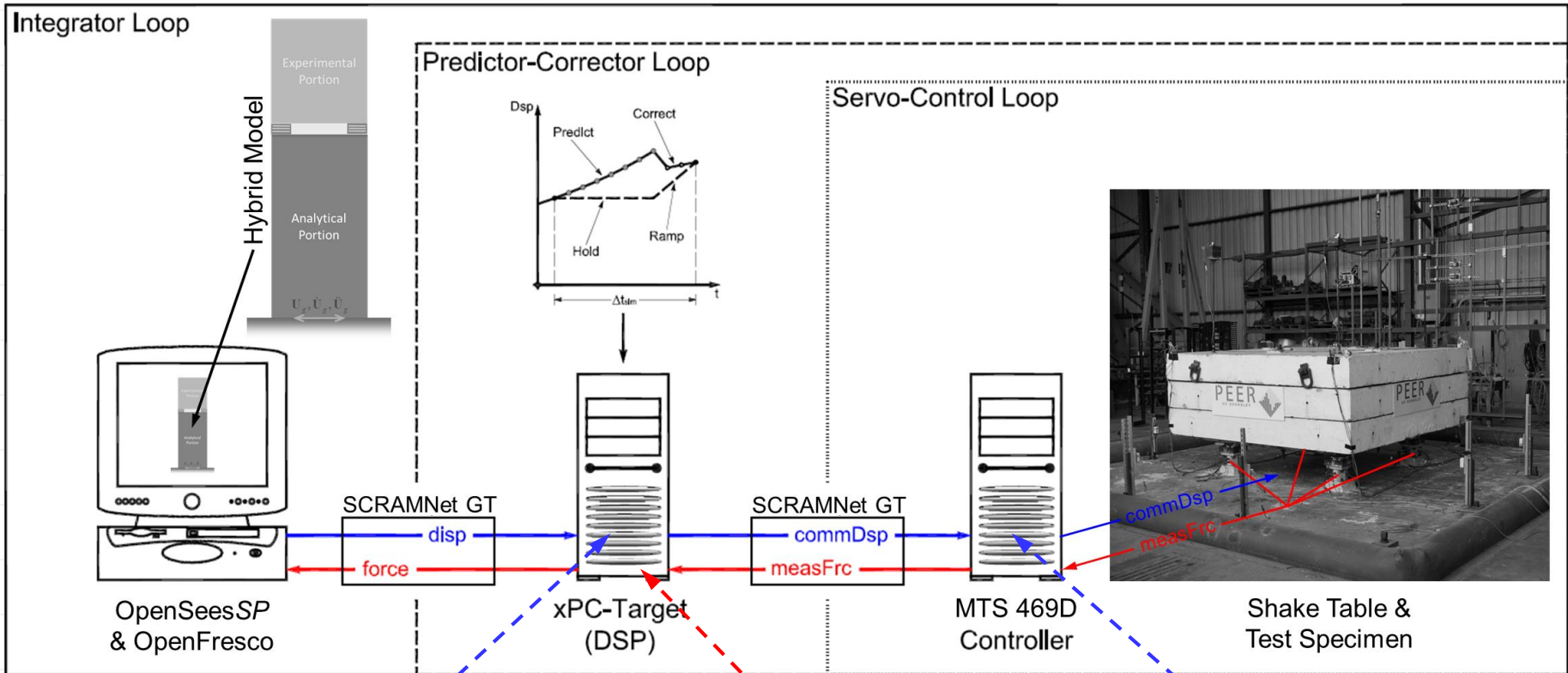

ATS delay  
compensator

filtering &  
noise reduction

TVC or other  
adv. ctrl. &  
force balancing

# Test Rehearsal

- Use FE-Adapter element method to simultaneously connect hybrid model to a numerically simulated test specimen

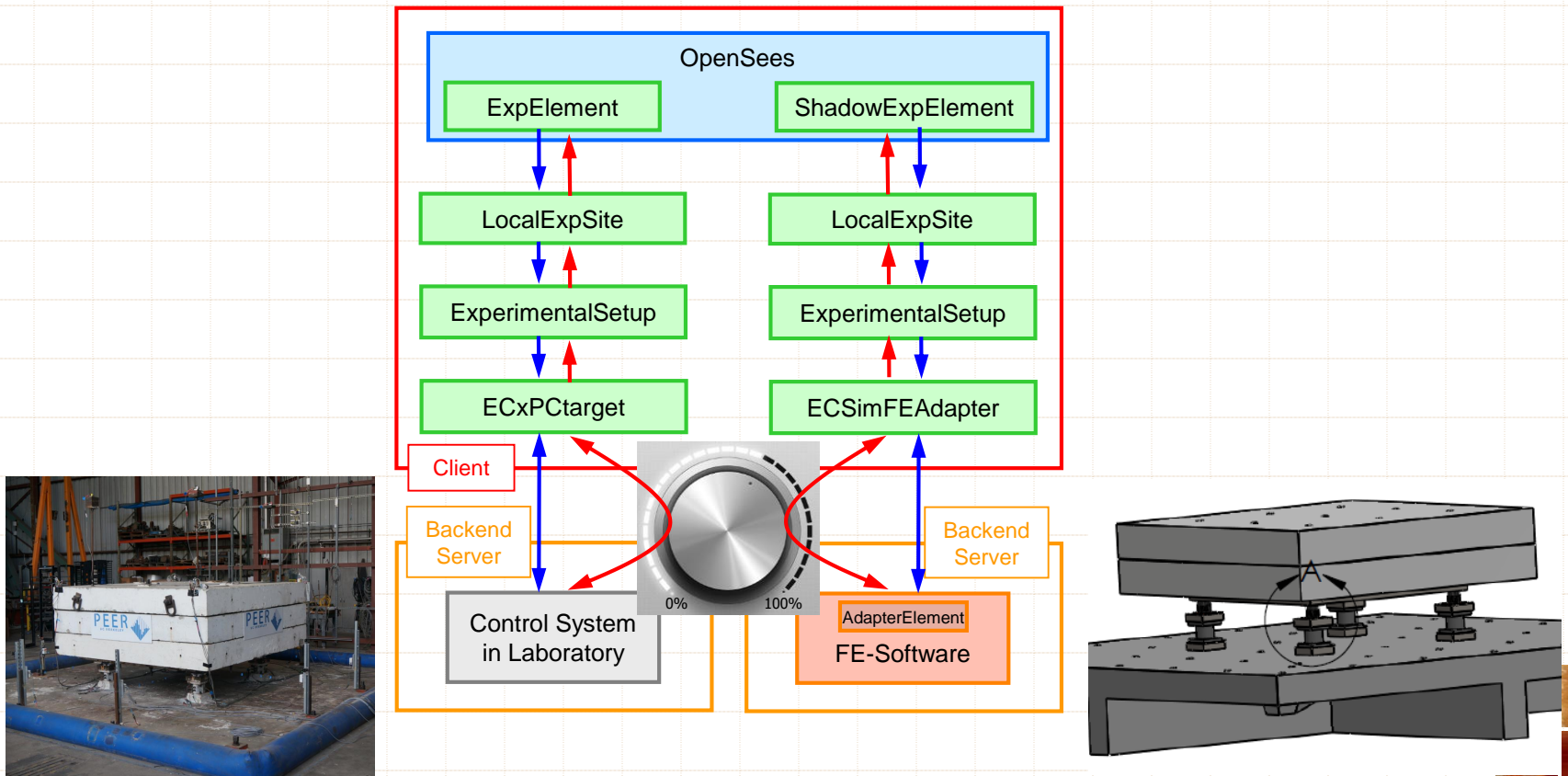

# Safety Precautions

## ★ At analysis side

- Set limit on displacement command (saturation and possibly rate limit)
- Set limit on actuator force so that once the limit is exceeded, the analysis model sends displacement commands to ramp both table and actuator to starting positions

## ★ At controller side

- Set both displacement and force limits so that once the limit is exceeded, the actuator pressure is switched to low, therefore, limiting the actuator force that can be applied to the specimen

# Bridge Application



# Shake Table + Structural Actuator



# Hybrid Model Development

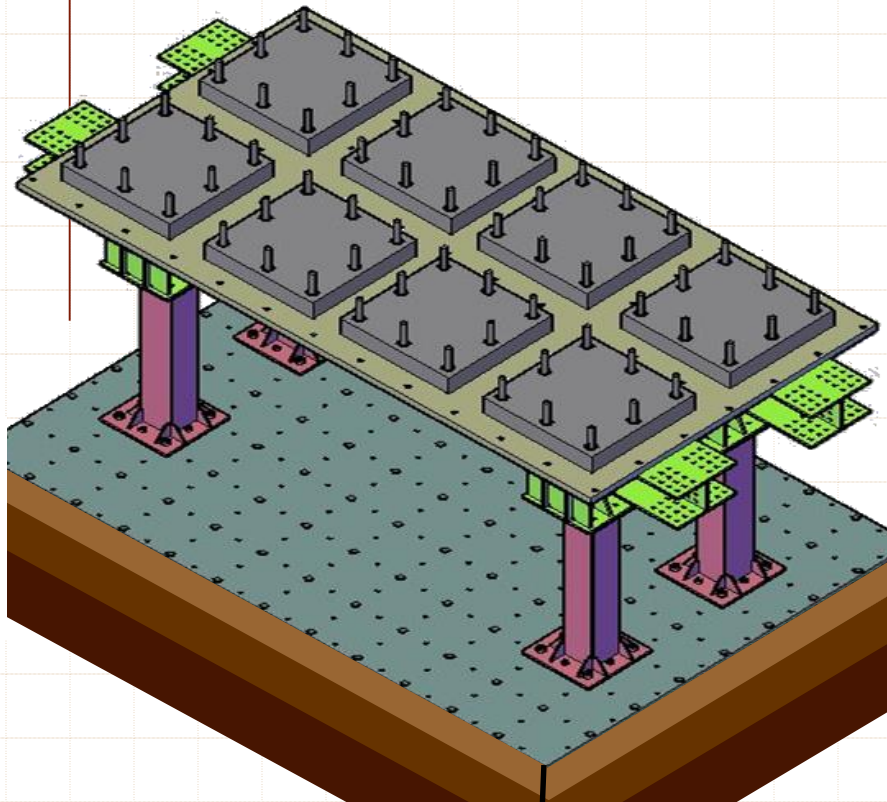

Actual Bridge Configuration  
(with foundation + soil)

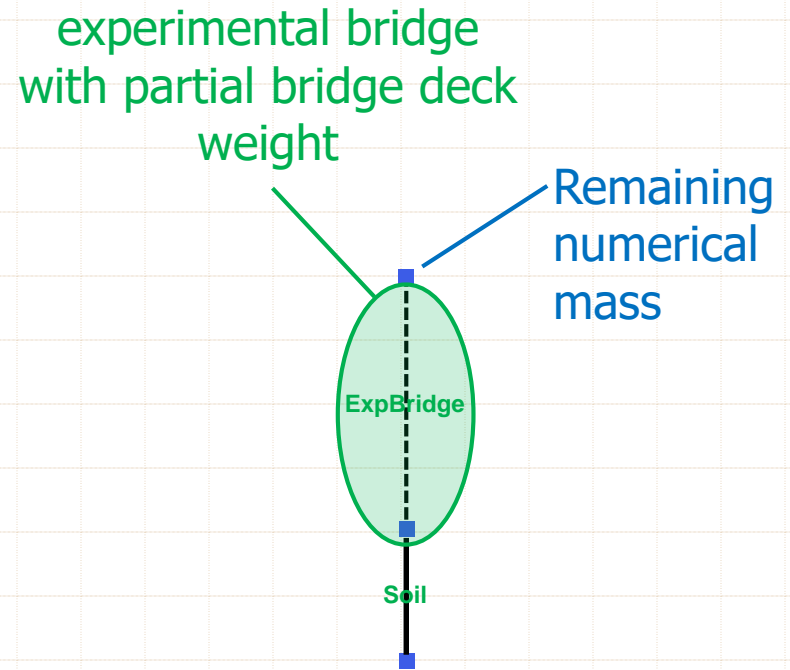

Simplified **Hybrid** OpenSees  
Model of Bridge (Stage 2)



# Experimental Setup

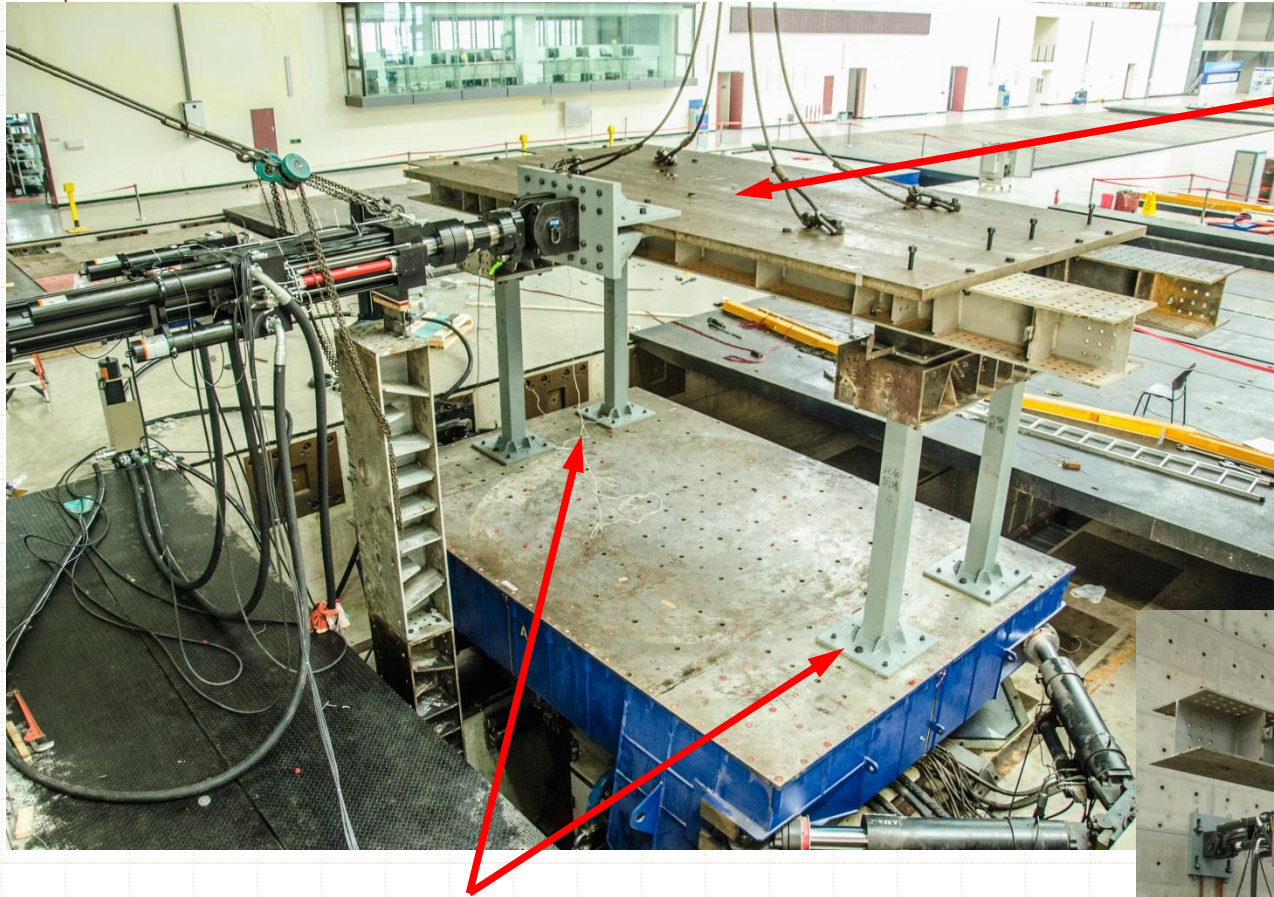

Partial-weight  
bridge deck

Using table observer to get shear  
forces at bottom of columns  
(load cells would be better)



# Movie of Test

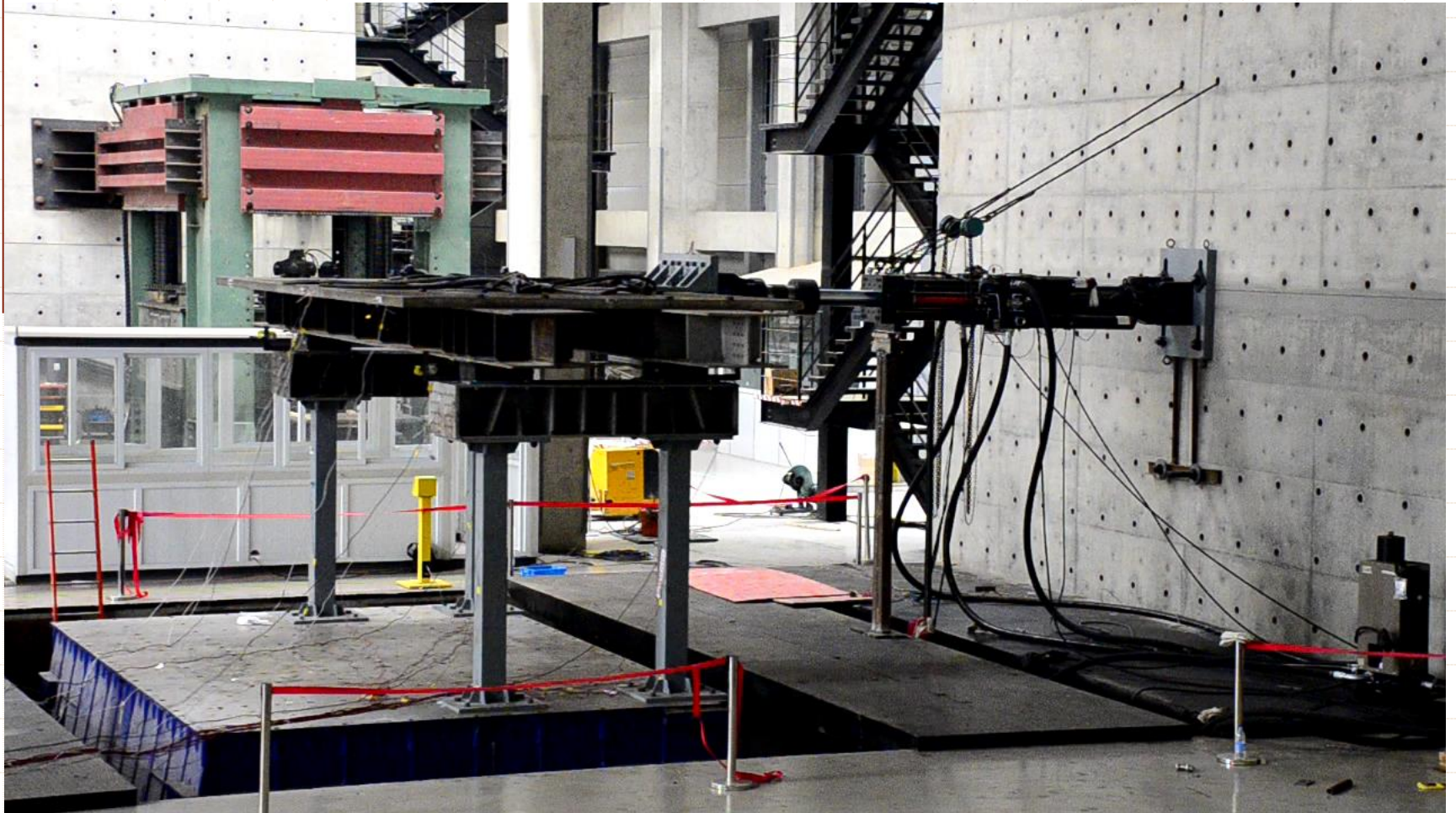

# Displ. Response Comparison

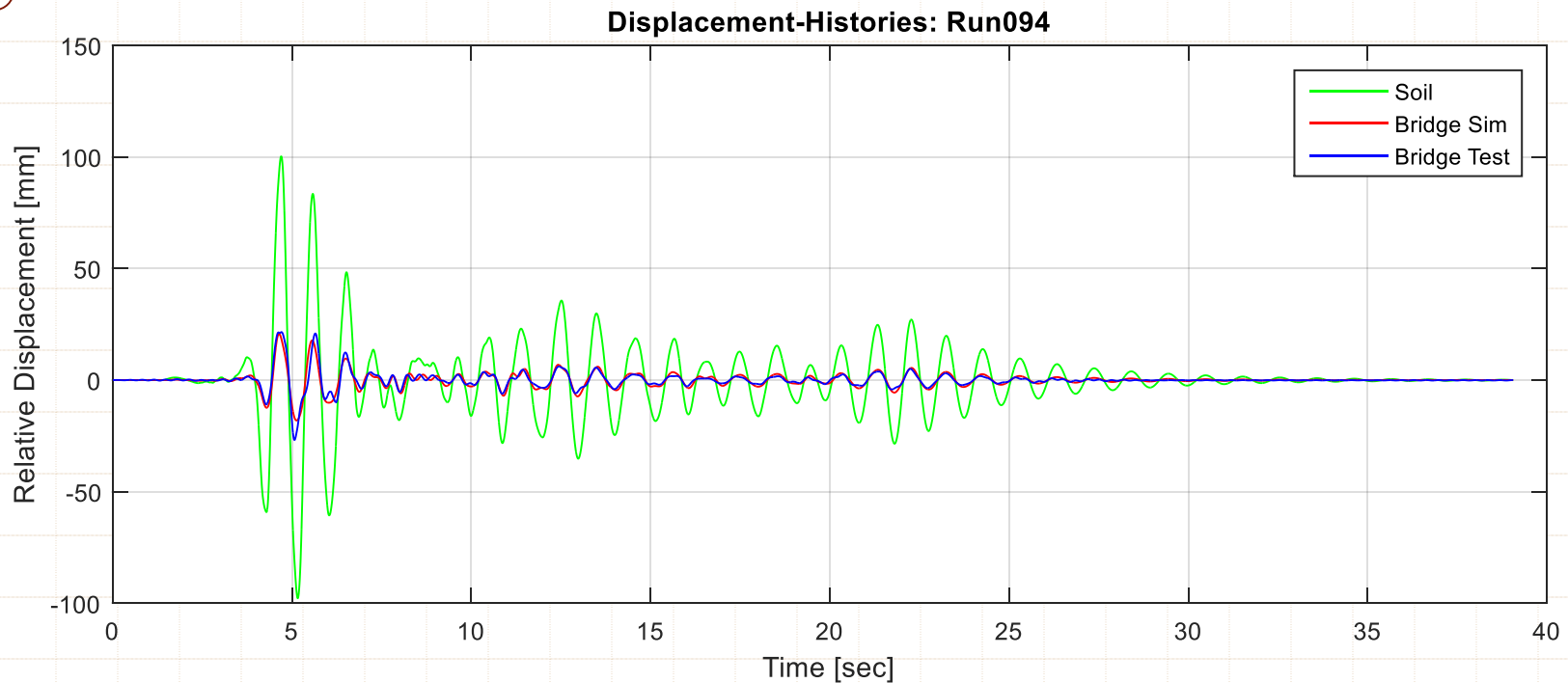

## ★ Accuracy is assessed using

- FFTs of tracking error
- Tracking Indicator (by Mercan and Ricles)
- RMS Error histories
- Comparison with purely numerical simulation

# Force Response Comparison

Force-Histories: Run094

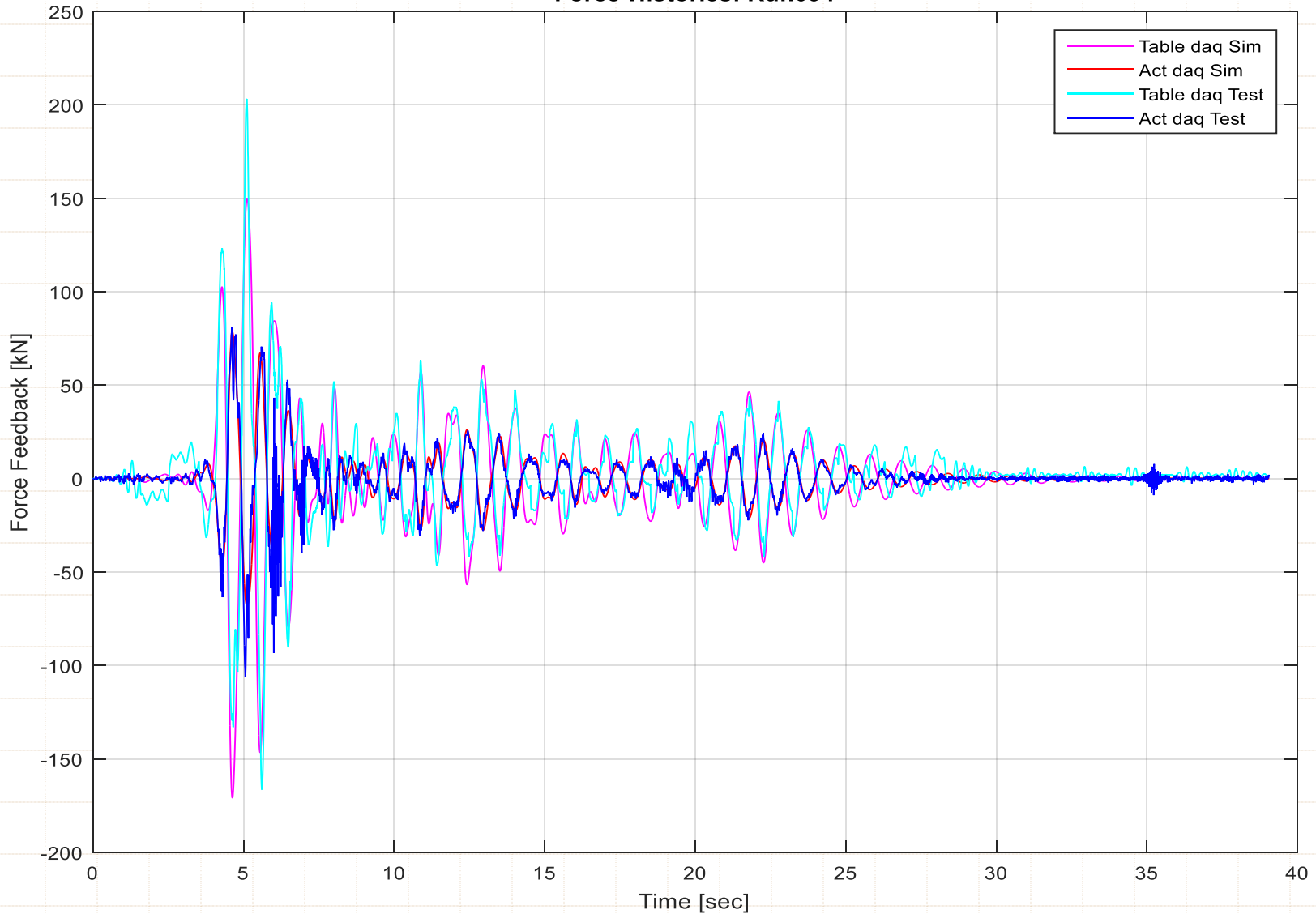

# Delay Assessment

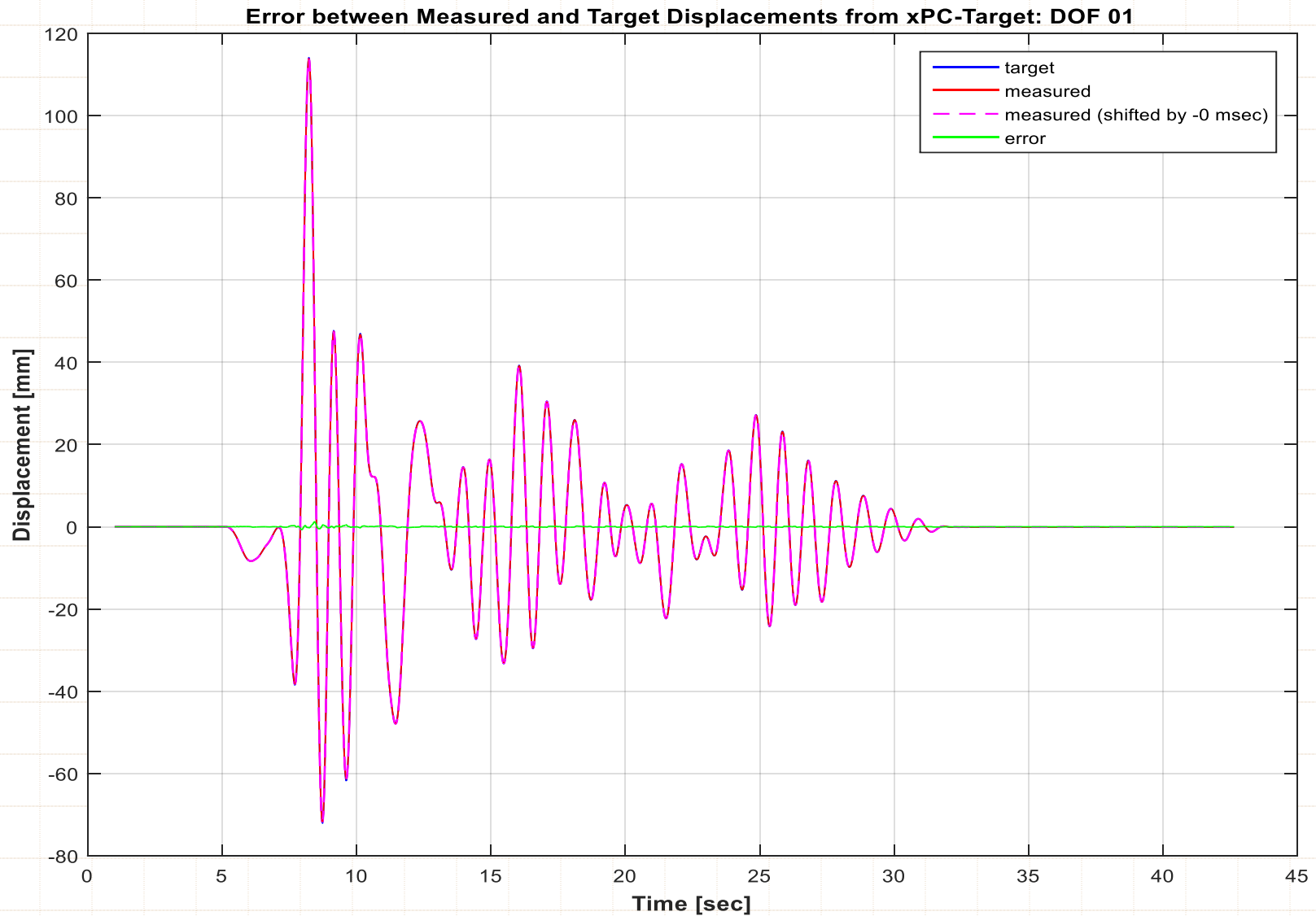

# Building Application



One 6DOF Shake Table

# PEER Shake Table Facility

- 20 ft x 20 ft table size
- Still the largest 6 DOF shake table in the US
- Can test structures, weighing 100,000 lbs, to horizontal accelerations of 1.5 g
- +/- 5 in. horizontal displacement capacity
- +/- 2 in. vertical displacement capacity
- +/- 40 in./sec velocity capacity



# Triple Friction Pendulum Bearings

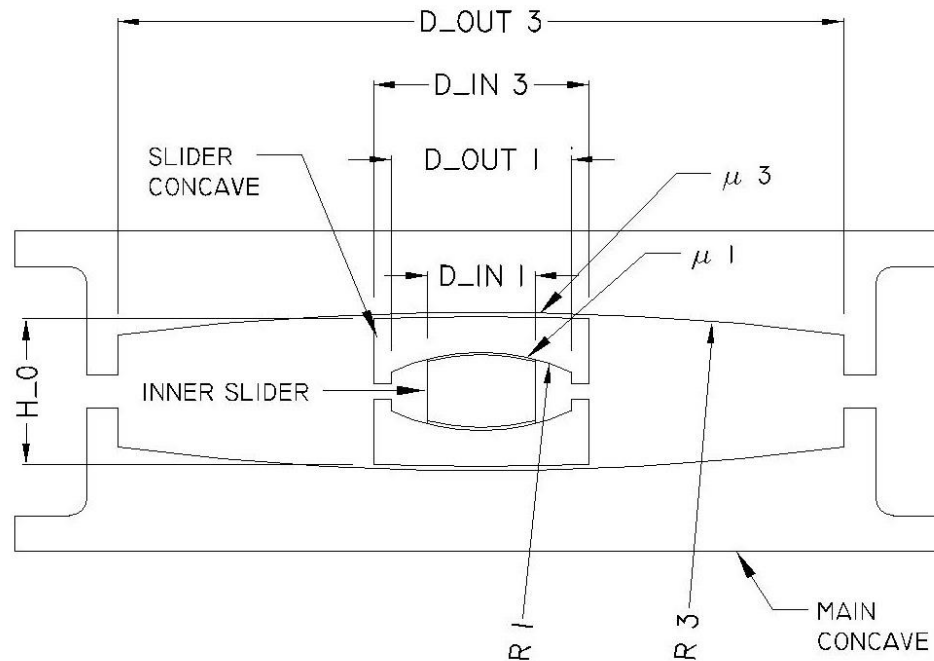

L1 (in.)	L2 (in.)	L3 (in.)
2.175	17.17	17.17

T1 (s)	T2 (s)	T3 (s)
0.67	1.41	1.87

	Inner sliding surfaces	Outer sliding surfaces
Dish radius (inch)	3	18.64
Height (inch)	1.65	2.94
Outer diameter (inch)	2.60	9
Inner diameter (inch)	1.75	3



# Analytical Substructure Parameters

Models without rotational DOF

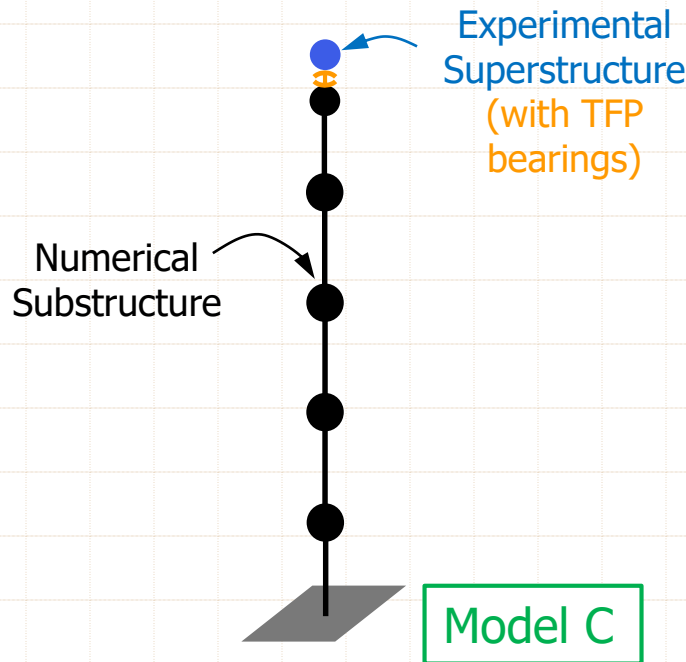

## 15-DOF Shear Building

$$W_{\text{tmd}} = 53 \text{ kip}$$
$$W_{\text{bldg}} = 450 \text{ kip}$$
$$f_{x1} = 1 \text{ Hz}$$
$$f_{y1} = 1.25 \text{ Hz}$$
$$f_{z1} = 9.8 \text{ Hz}$$

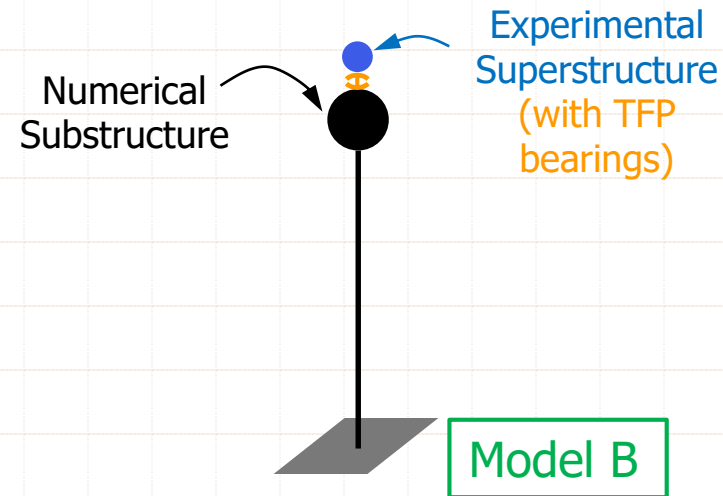

## 3-DOF Equivalent Model

$$W_{\text{tmd}} = 53 \text{ kip}$$
$$W_{\text{bldg}} = 0.886 * 450 \text{ kip}$$
$$f_{x1} = 1 \text{ Hz}$$
$$f_{y1} = 1.25 \text{ Hz}$$
$$f_{z1} = 11 \text{ Hz}$$

# Analytical Substructure Parameters

Models with rotational DOF

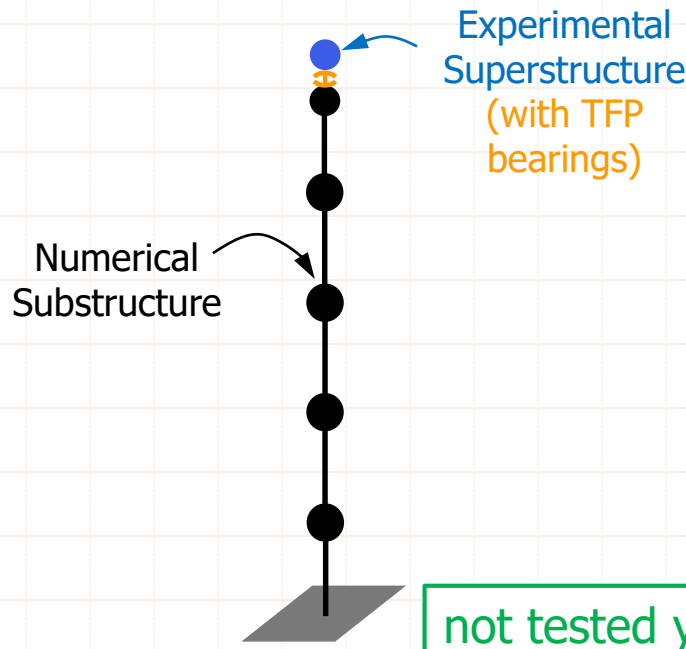

## 30-DOF Flexural Building

$$W_{\text{tmd}} = 53 \text{ kip}$$

$$W_{\text{bldg}} = 450 \text{ kip}$$

$$f_{x1} = 1 \text{ Hz}$$

$$f_{y1} = 1.25 \text{ Hz}$$

$$f_{z1} = 9.8 \text{ Hz}$$

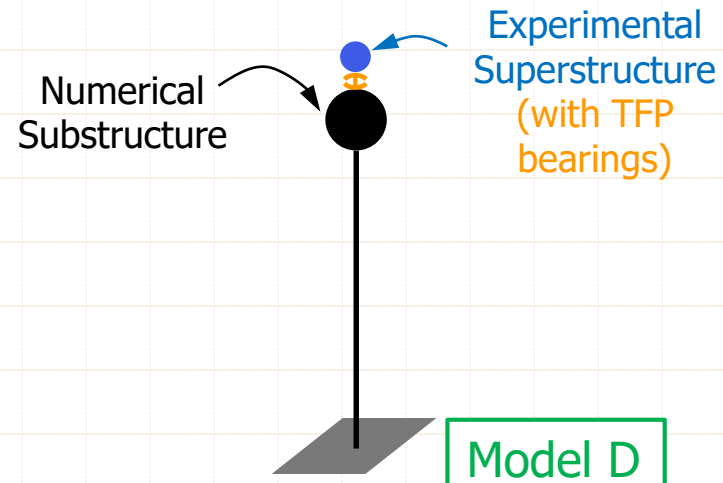

## 5-DOF Equivalent Model

$$W_{\text{tmd}} = 53 \text{ kip}$$

$$W_{\text{bldg}} = 0.849 * 450 \text{ kip}$$

$$f_{x1} = 1 \text{ Hz}$$

$$f_{y1} = 1.25 \text{ Hz}$$

$$f_{z1} = 11 \text{ Hz}$$

# Analytical Substructure Parameters

Tall Building Model E

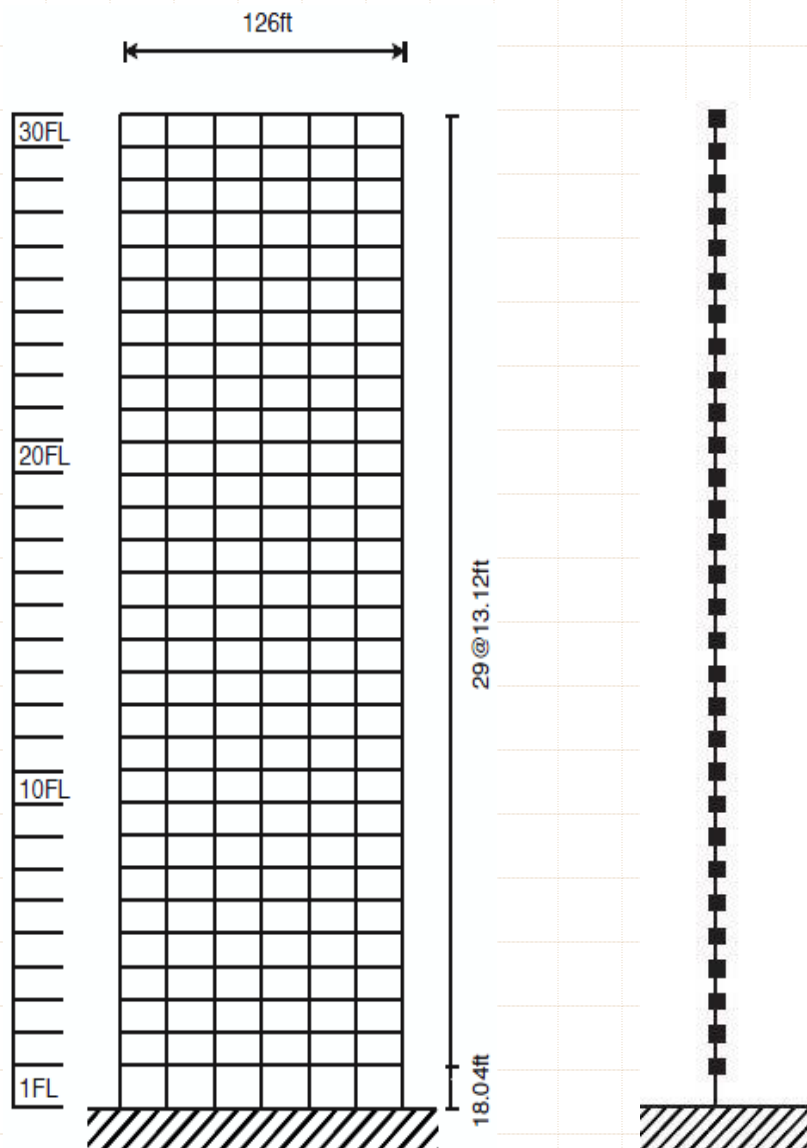

## 30-DOF Shear Building

$$W_{\text{tmd}} = 53 \text{ kip}$$

$$W_{\text{bldg}} = 63000 \text{ kip}$$

$$SF = 120$$

$$SL = \text{sqrt}(SF)$$

$$SI = SL^4$$

$$ST = \text{sqrt}(SL)$$

$$SV = SL/ST$$

$$f_{x1} = 0.27 \text{ Hz}$$

$$T_{x1} = 3.7 \text{ sec}$$

# Movie of Test



# Delay Assessment

Error between Measured and Target Displacements from xPC-Target: DOF 01

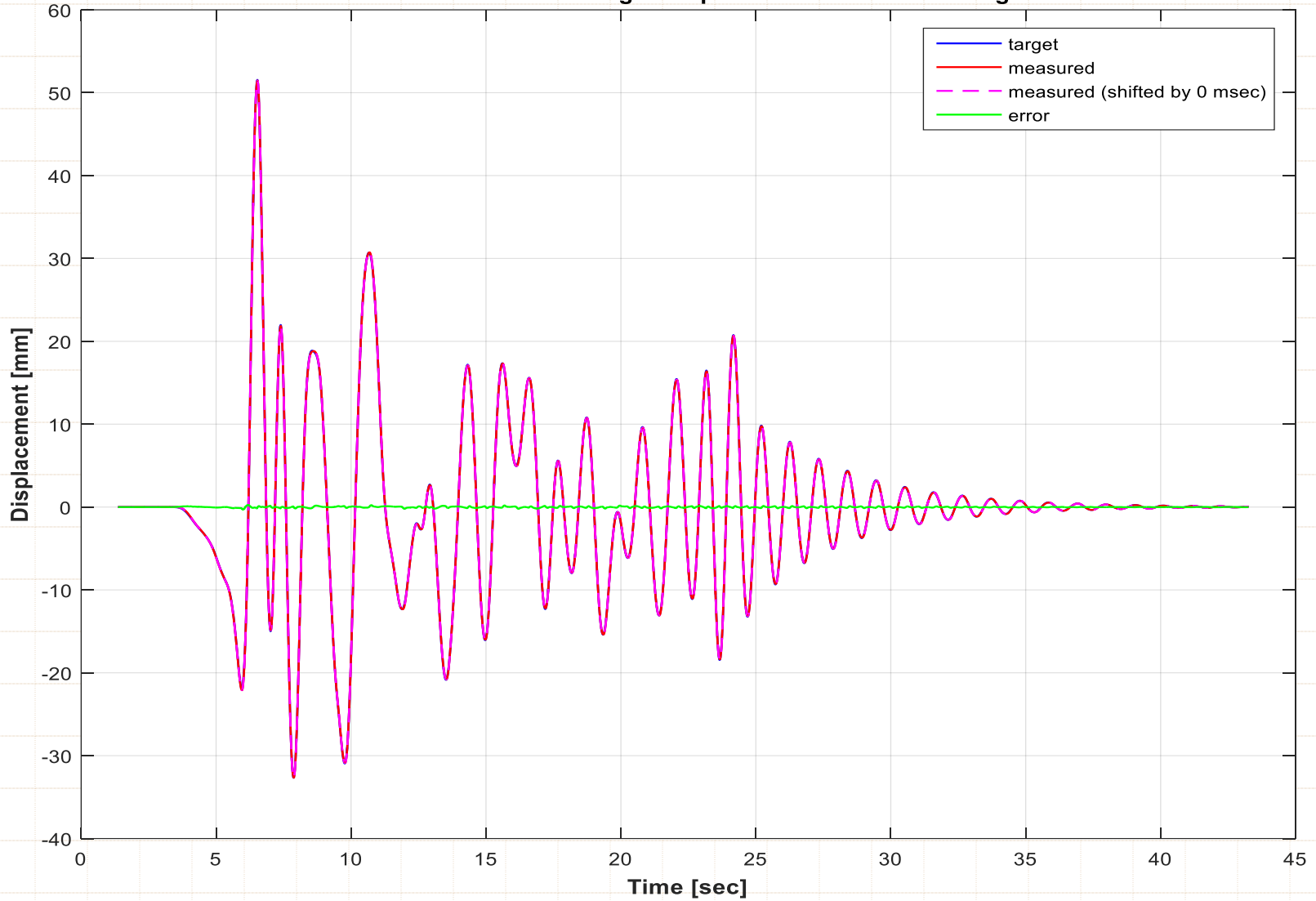

# Delay Assessment

Error between Measured and Target Displacements from xPC-Target: DOF 02

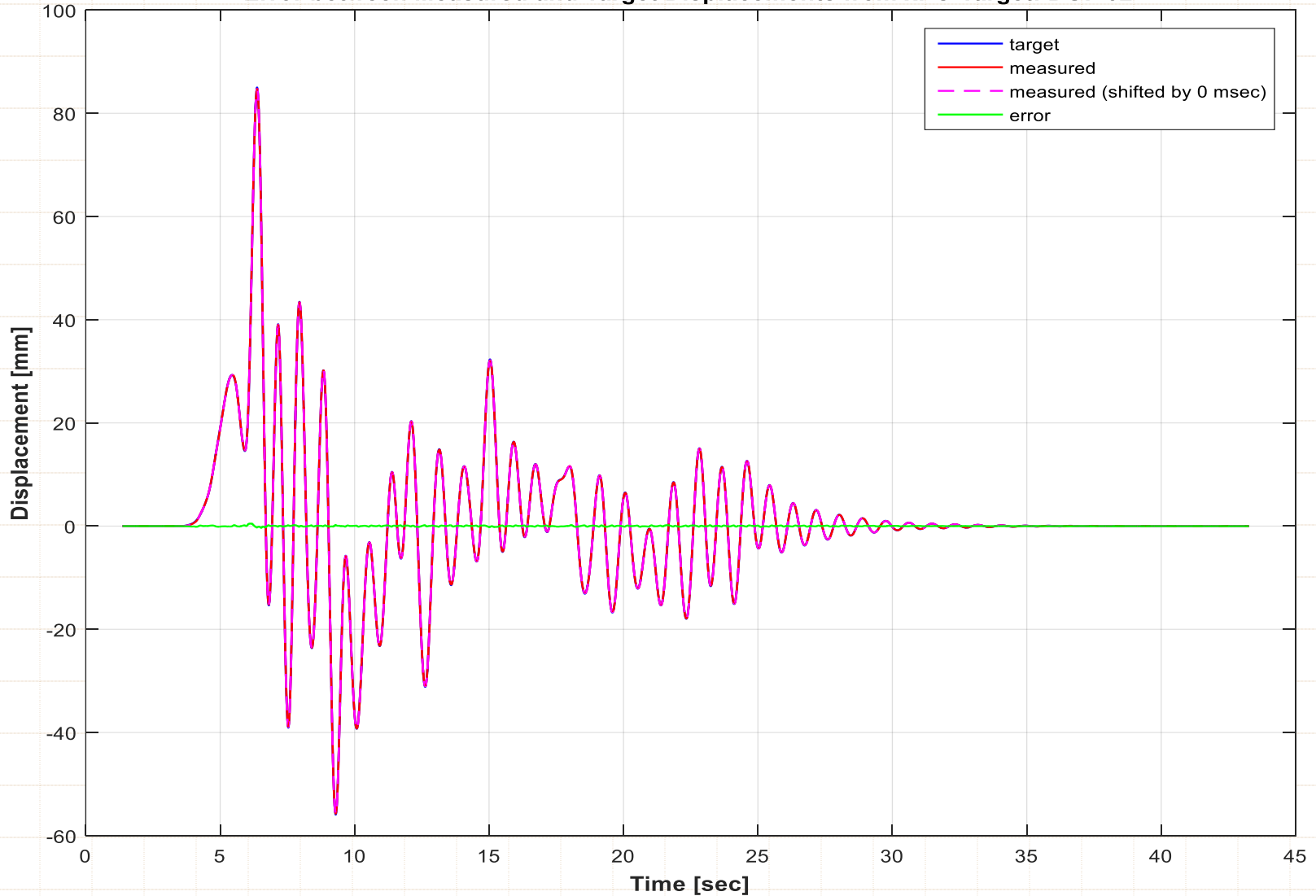

# Delay Assessment

Error between Measured and Target Displacements from xPC-Target: DOF 03

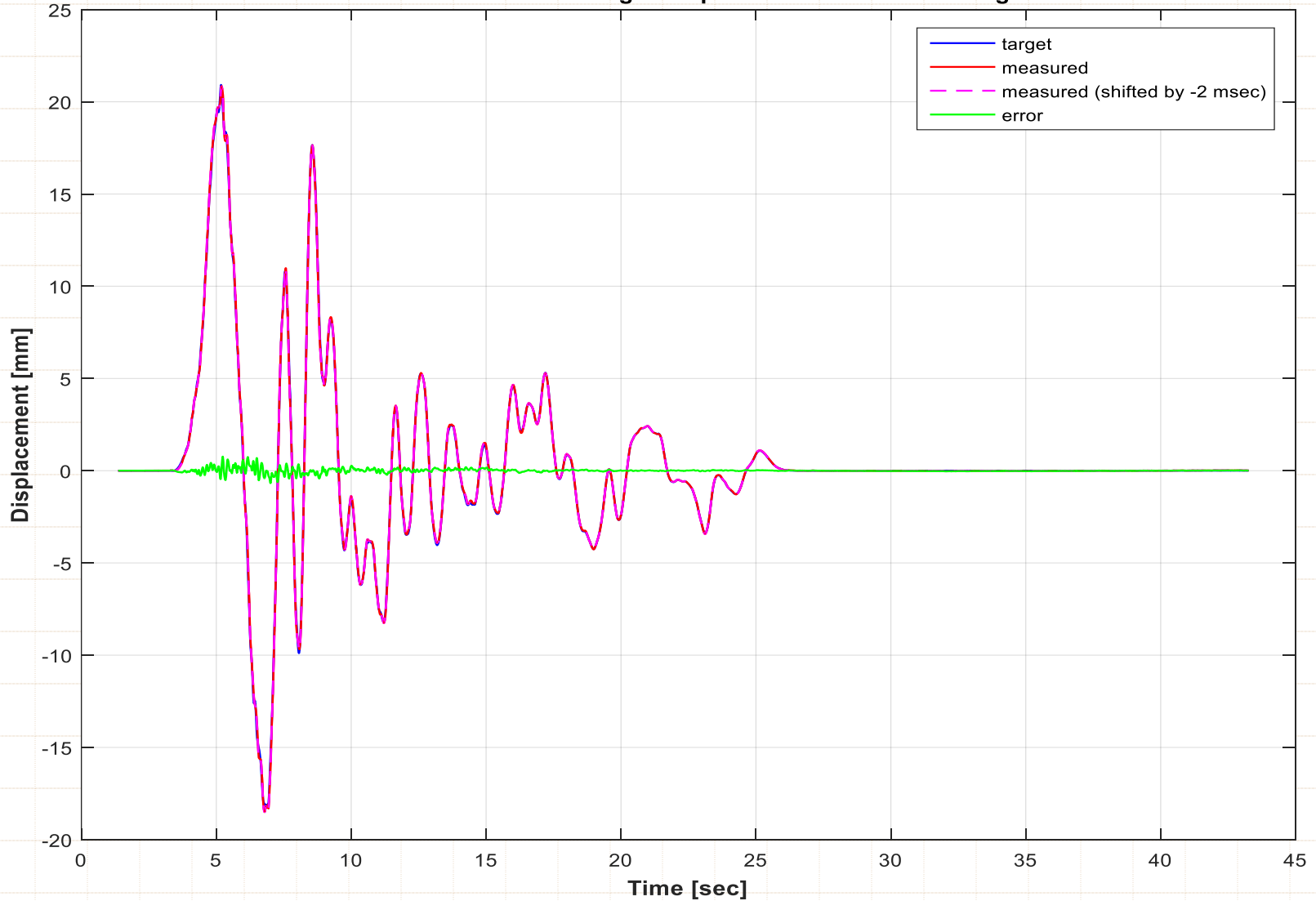

# Tracking Indicator & NRMSE[%]

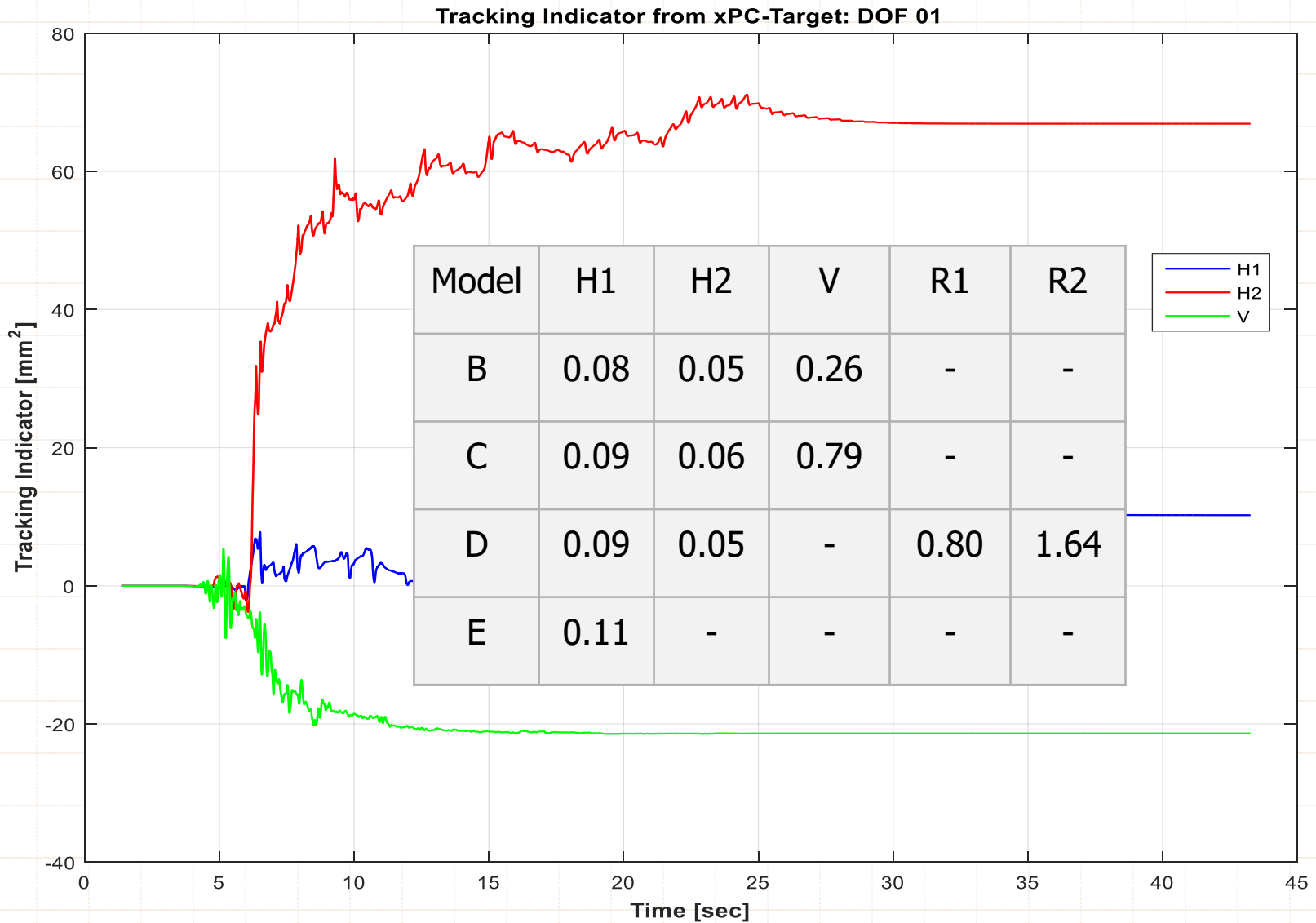



# Filtering of Force Feedback

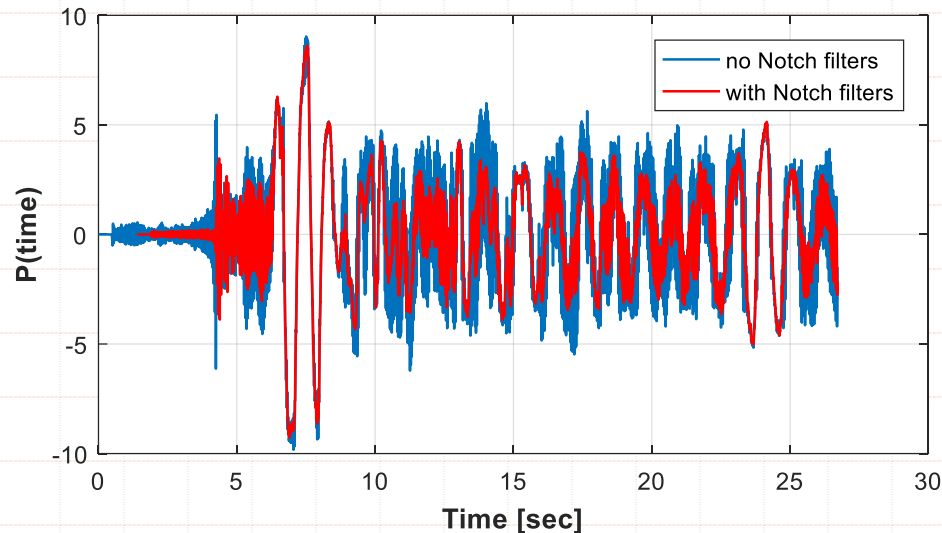

- Future work required
- Investigate other filtering techniques
- Investigate Kalman filtering techniques (can this be applied to force feedbacks using an predictive analysis model in parallel?)

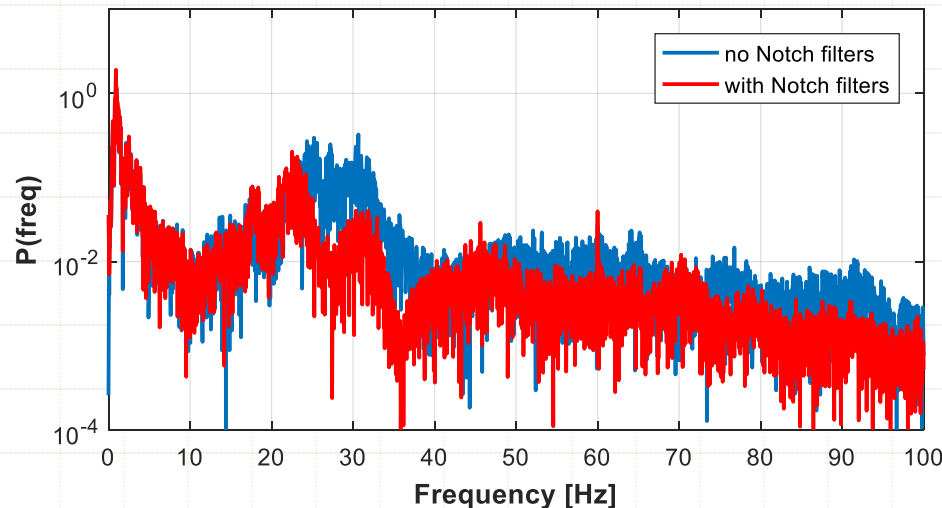

# Building Response Modification

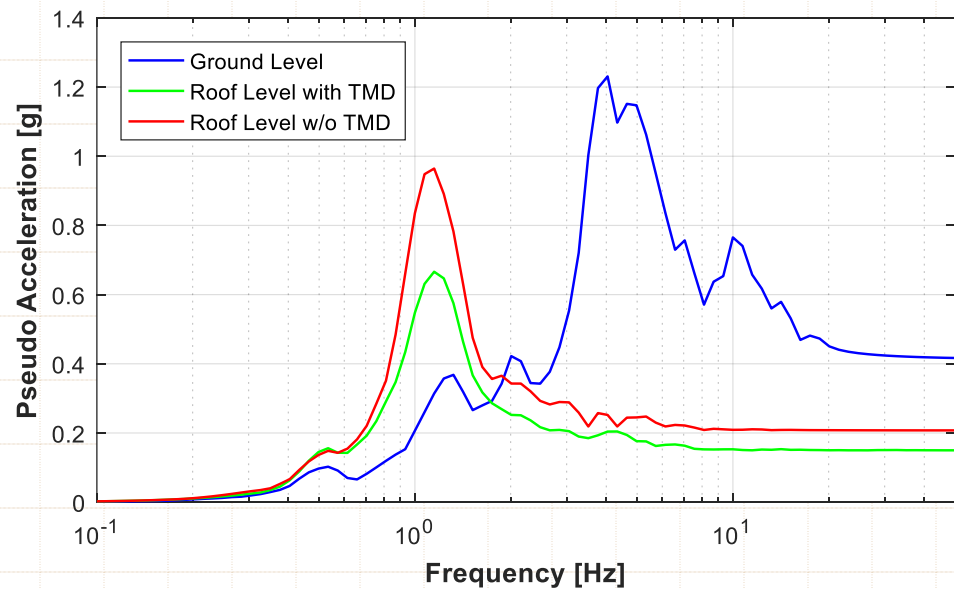
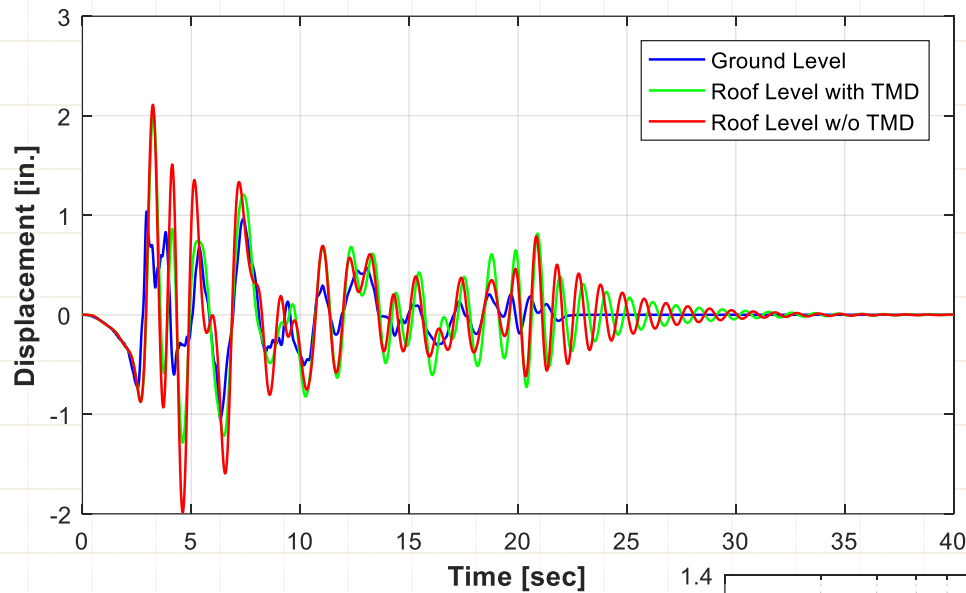

# Summary & Conclusions

- ✦ Ability to drive a MDOF shake table through a finite element model
- ✦ Shake table platform can thus represent a floor or the roof of a building, the motion on top of a bridge column, or the ground surface on top of a soil domain
- ✦ Performed large-scale RTHS where a shake table is combined with a dynamic structural actuator applied to a bridge
- ✦ Ability to perform parameter studies

# Summary & Conclusions

- ★ Use whenever the dynamics of the test specimen significantly affects the response of the supporting structure or soil and, therefore, alters the required input to the shake table as testing progresses
- ★ ATS delay compensator worked very well
- ★ Need to further investigate sensor noise reduction methods to improve feedback signals (look into Kalman filters)

*NHERI Lehigh Researcher's Workshop: Advanced Simulation for  
Natural Hazards Mitigation, Lehigh, 12/5-12/6/2016*

Questions?  
Thank you!

<http://openfresco.berkeley.edu>

